



FOLDING DOOR SYSTEMS

FITTING INSTRUCTIONS - ALL CONFIGURATIONS

IMPORTANT

Please note: You can only assemble these door configurations by using the frame provided. Your warranty will be invalid if other alternatives are used.

All loads are taken by the top track to ensure smooth, light operation and long life.

Prior to installing this doorset, inspect for damage and do not proceed to fit if any noticeable damage or defect is evident. This doorset should be stored in a dry flat location before installation.

CAUTION



SAFETY: This product needs to be installed by a qualified competent carpenter/joiner with assistance. Two people are required to carry out the installation, as some components are heavy.

The outer frame requires fixing to the supporting structure above the opening.

The opening **MUST** be capable of carrying the load of the doorset in all conditions.

SYSTEM CONTENTS

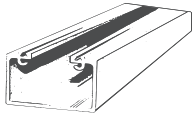
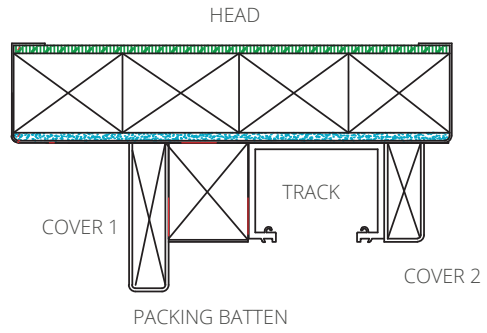
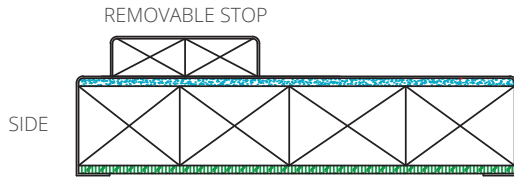

TRACK



HARDWARE BOX

HEAD	3000 X 133 X 30 MM
SIDES X 2	2100 X 133 X 30 MM
REMOVABLE STOPS X 2	2100 X 45 X 12 MM
COVER 1	3000 X 45 X 12 MM
COVER 2	3000 X 30 X 12 MM
PACKING BATTEN	3000 X 30 X 24 MM

PLEASE REFER TO THE HARDWARE CHECK TABLE ON PAGE 3

THE HARDWARE PARTS EXPLAINED

<p>BW3-35HSS</p> <p>STRAIGHT HINGE HANDLE SET</p>	<p>BW7-35HSS</p> <p>OFFSET HINGE HANDLE SET</p>	<p>BWS1F-35HSS</p> <p>PIVOT DOOR SET</p>	<p>BWS2F-35HSS</p> <p>END SET CARRIER</p>	<p>BWS4F-35CHSS</p> <p>INTERMEDIATE CARRIER SET</p>	<p>360SN</p> <p>FLUSH BOLT</p>
---	---	--	---	---	--------------------------------

CHECK YOUR HARDWARE SET AGAINST THE SET ORDERED

BWS1F-35HSS	Pivot Set 35 KG Satin Stainless	1
BWS4-35CHSS	Intermediate Carrier Set 35KG Satin Stainless Flush	1
BW7-35HSS	Offset Hinge Handle Set 35KG Satin Stainless	1
360SN	Non Locking Flush bolt 110mm long	2
120-A20	Aluminium Top Track - 2000mm	1

2+0 to suit 610mm doors		
Product Code DE35-D61/20		
BWS1F-35HSS	Pivot Set 35 KG Satin Stainless	1
BWS2-35CHSS	End Carrier Set 35KG Satin Stainless Flush	1
BW3-35HSS	Straight Hinge Handle Set	1
360SN	Non Locking Flush bolt 110mm long	2
120-A20	Aluminium Top Track - 2000mm	1

2+1 to suit 610mm doors		
Product Code - DE35-D61/21		
BWS1F-35HSS	Pivot Set 35 KG Satin Stainless	2
BWS2-35CHSS	End Carrier Set 35KG Satin Stainless Flush	1
BW3-35HSS	Straight Hinge Handle Set	1
360SN	Non Locking Flush bolt 110mm long	2
120-A20	Aluminium Top Track - 2000mm	1

4+0 to suit 610mm doors		
Product Code - DE35-D61/40		
BWS1F-35HSS	Pivot Set 35 KG Satin Stainless	1
BWS2-35CHSS	End Carrier Set 35KG Satin Stainless Flush	1
BWS4-35CHSS	Intermediate Carrier Set 35KG Satin Stainless Flush	1
BW7-35HSS	Offset Hinge Handle Set	2
360SN	Non Locking Flush bolt 110mm long	4
120-A25	Aluminium Top Track - 2500mm	1

3+1 to suit 610mm doors		
Product Code - DE25-D61/31		
BWS1F-35HSS	Pivot Set 35 KG Satin Stainless	2
BWS4-35CHSS	Intermediate Carrier Set 35KG Satin Stainless Flush	1
BW7-35HSS	Offset Hinge Handle Set 35KG Satin Stainless	1
360SN	Non Locking Flush bolt 110mm long	2
120-A25	Aluminium Top Track - 2500mm	1

BWS1F-35HSS	Pivot Set 35 KG Satin Stainless	1
BWS4-35CHSS	Intermediate Carrier Set 35KG Satin Stainless Flush	1
BW7-35HSS	Offset Hinge Handle Set 35KG Satin Stainless	1
360SN	Non Locking Flush bolt 110mm long	2
120-A25	Aluminium Top Track - 2500mm	1

2+0 to suit 686mm doors		
Product Code DE35-D68/20		
BWS1F-35HSS	Pivot Set 35 KG Satin Stainless	1
BWS2-35CHSS	End Carrier Set 35KG Satin Stainless Flush	1
BW3-35HSS	Straight Hinge Handle Set	1
360SN	Non Locking Flush bolt 110mm long	2
120-A20	Aluminium Top Track - 2000mm	1

2+1 to suit 686mm doors		
Product Code DE35-D68/21		
BWS1F-35HSS	Pivot Set 35 KG Satin Stainless	2
BWS2-35CHSS	End Carrier Set 35KG Satin Stainless Flush	1
BW3-35HSS	Straight Hinge Handle Set	1
360SN	Non Locking Flush bolt 110mm long	2
120-A25	Aluminium Top Track - 2500mm	1

4+0 to suit 686mm doors		
Product Code DE35-D68/40		
BWS1F-35HSS	Pivot Set 35 KG Satin Stainless	1
BWS2-35CHSS	End Carrier Set 35KG Satin Stainless Flush	1
BWS4-35CHSS	Intermediate Carrier Set 35KG Satin Stainless Flush	1
BW7-35HSS	Offset Hinge Handle Set	2
360SN	Non Locking Flush bolt 110mm long	4
120-A30	Aluminium Top Track - 3000mm	1

3+1 to suit 686mm doors		
Product Code DE35-D68/31		
BWS1F-35HSS	Pivot Set 35 KG Satin Stainless	2
BWS4-35CHSS	Intermediate Carrier Set 35KG Satin Stainless Flush	1
BW7-35HSS	Offset Hinge Handle Set 35KG Satin Stainless	1
360SN	Non Locking Flush bolt 110mm long	2
120-A30	Aluminium Top Track - 3000mm	1

CONFIGURATIONS

OPENING WIDTH		CONFIGURATIONS		
610MM	686MM			
1235MM	1387MM		2 + 0	
1848MM	2076MM		3 + 0	
1848MM	2076MM		2 + 1	
2461MM	2765MM		4 + 0	
2461MM	2765MM		3 + 1	

DOOR HARDWARE SET ORIENTATION

PATTERNS ARE REVERSIBLE. HANDLE AND LATCH NOT SUPPLIED.

HARDWARE POSITIONS

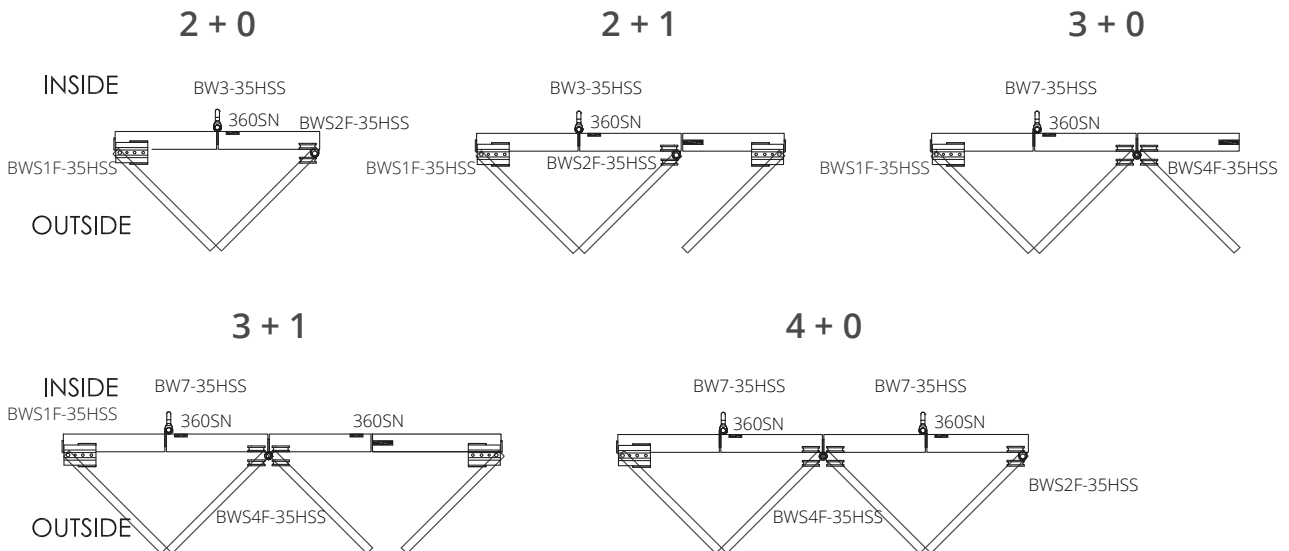

OPENING PREPARATION

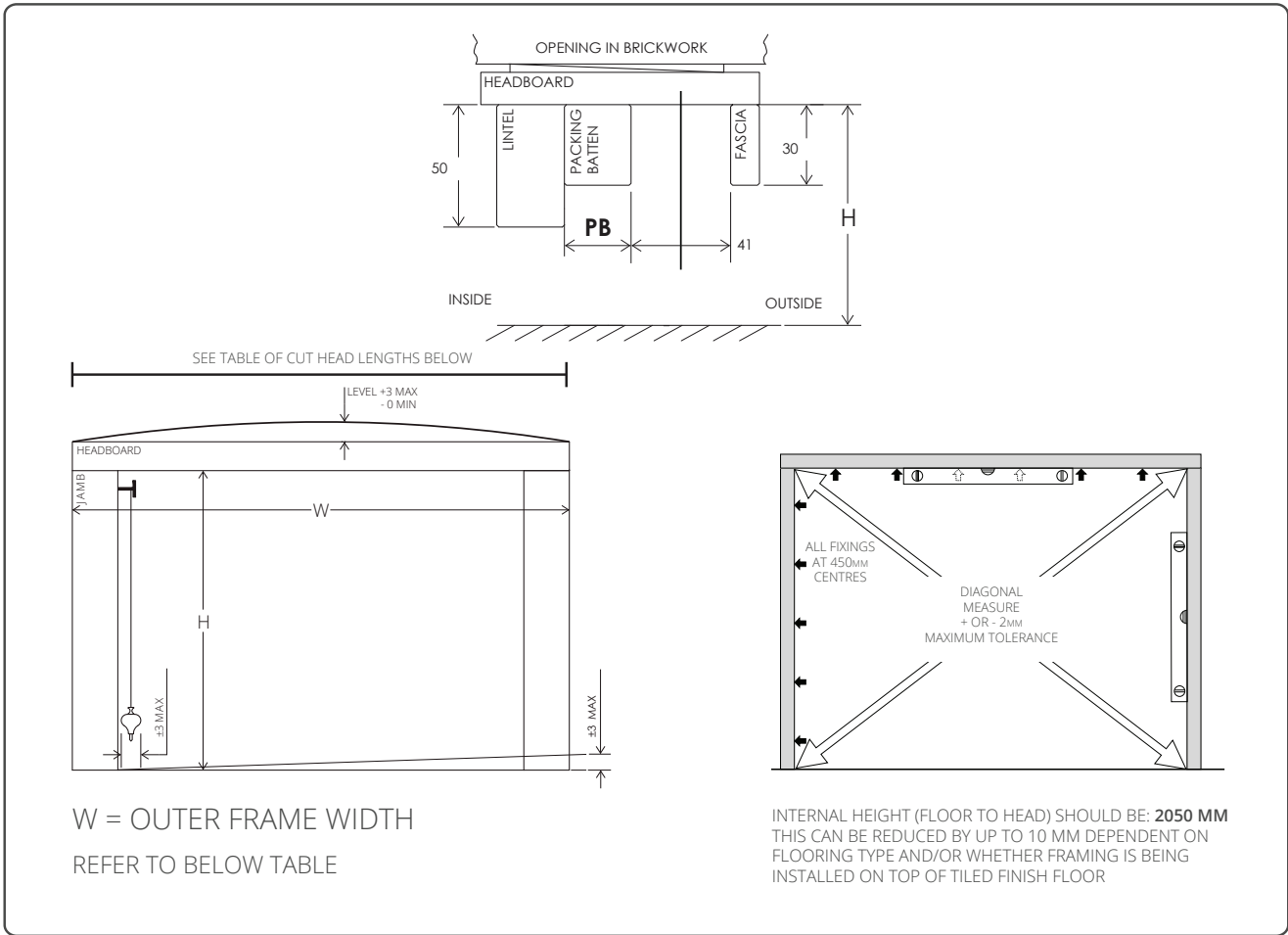

CUT THE FRAME HEAD TO BELOW LENGTH

OUTER FRAME WIDTH (W)		CONFIGURATIONS	HARDWARE PACK CODE	
610MM	686MM		610MM	686MM
1295MM	1447MM	2 + 0	DE35-D61/20	DE35-D68/20
1908MM	2136MM	3 + 0	DE35-D61/30	DE35-D68/30
1908MM	2136MM	2 + 1	DE35-D61/21	DE35-D68/21
2521MM	2825MM	4 + 0	DE35-D61/40	DE35-D68/40
2521MM	2825MM	3 + 1	DE25-D61/31	DE35-D68/31

ONCE THE FRAME IS INSTALLED CHECK THE INTERNAL REBATE SIZE BEFORE INSTALLING TRACK AND HARDWARE. FRAME SHOULD BE SQUARE AND PLUMB WITH AN INTERNAL REBATE WIDTH OF W (OUTER FRAME WIDTH) MINUS 60MM

TRACK PREPARATION

WHEN CUTTING TRACK TAKE OUTER FRAME WIDTH (W) MINUS 65 MM

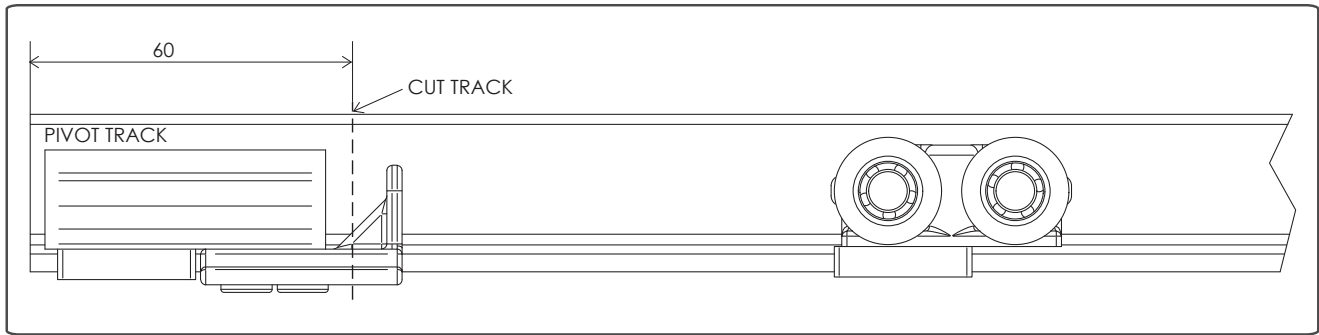

NOTE: YOU CAN EITHER INSTALL TRACK WITH HARDWARE ALREADY INSIDE TRACK OR CUT A 60 MM SECTION OFF THE END TO FEED HARDWARE IN AFTER FITTING THE TRACK INTO THE FRAME.

INSTALLING TRACK

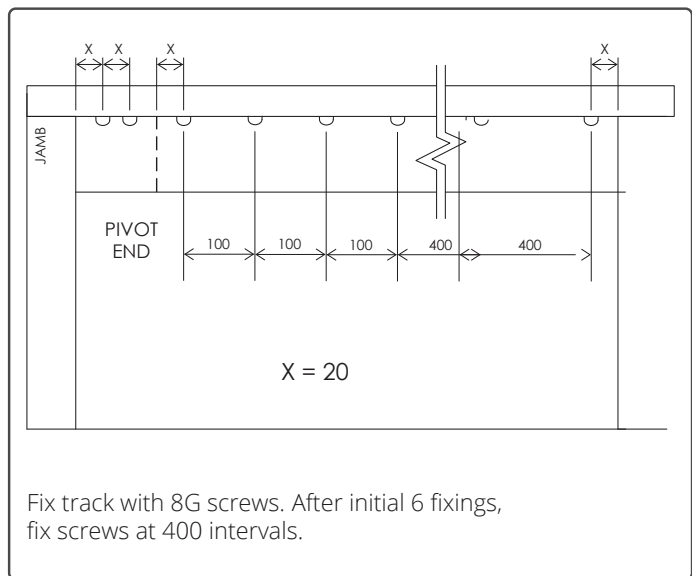
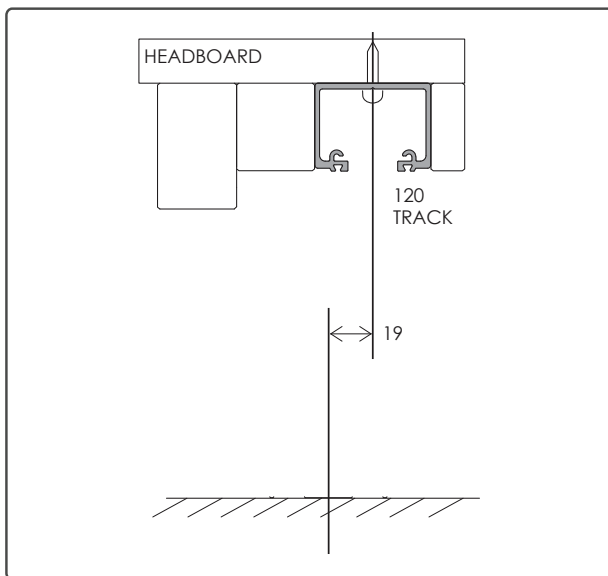

Fix track with 8G screws. After initial 6 fixings, fix screws at 400 intervals.

HINGE INSTALLATION

PILOT HOLE OF Ø2.5MM RECOMMENDED. PANEL THICKNESS 30 MINIMUM.

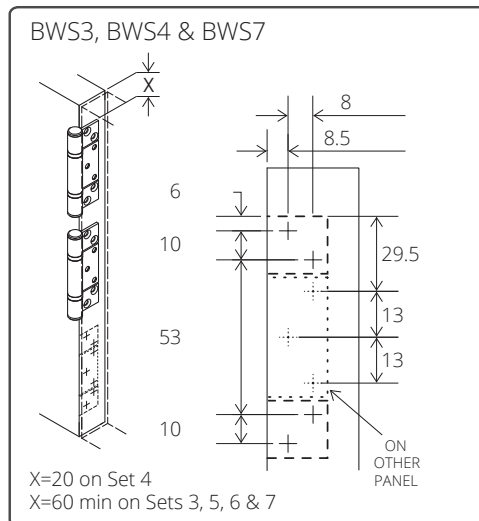
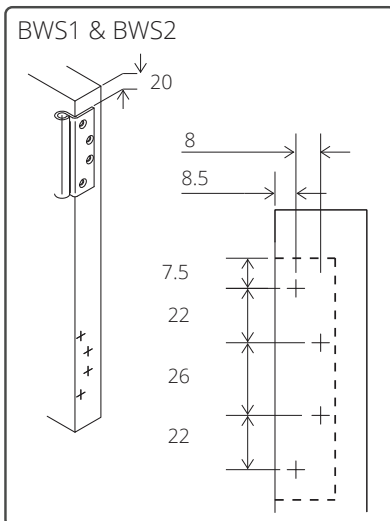

FLUSH BOLT POSITION

SEE PAGE 2 FOR FLUSH BOLT LOCATION FOR ALL CONFIGURATIONS, ROUTER AVAILABLE

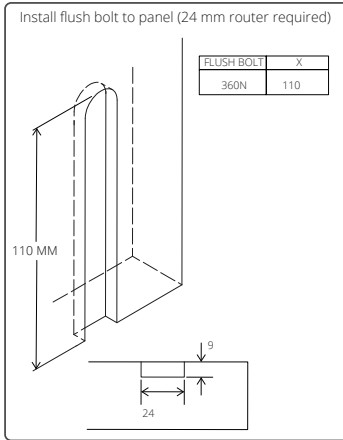

FITTING BOTTOM PIVOT

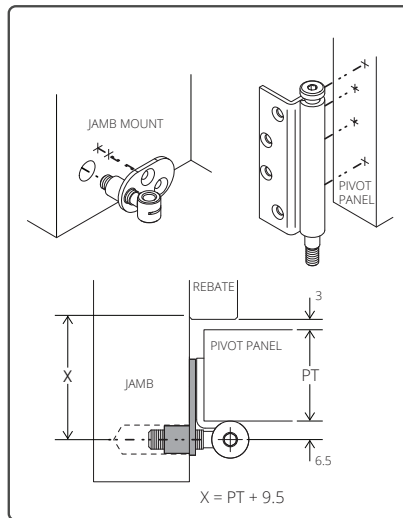
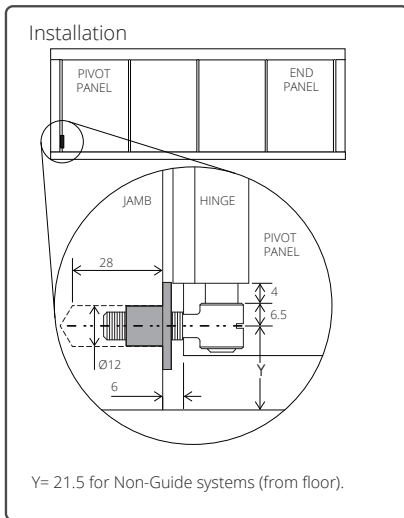

DETERMINING SYSTEM ORIENTATION

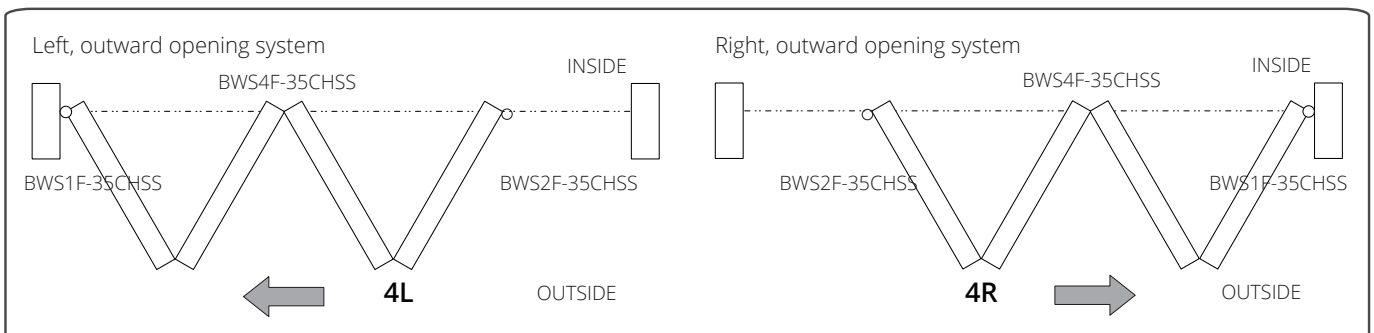

DETERMINING SYSTEM ORIENTATION

RECOMMENDED BEFORE INSTALLATION

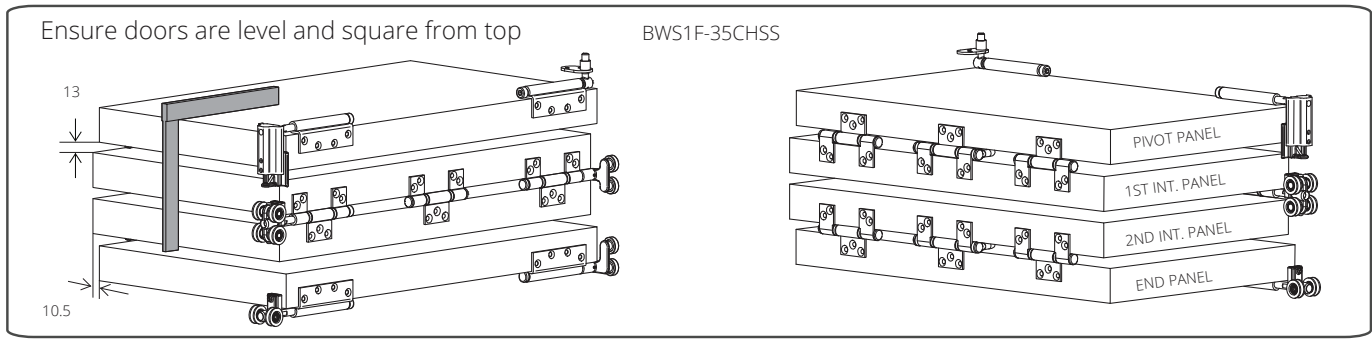

DETERMINING SYSTEM ORIENTATION

RECOMMENDED BEFORE INSTALLATION

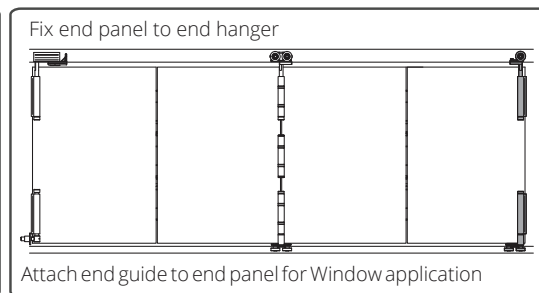
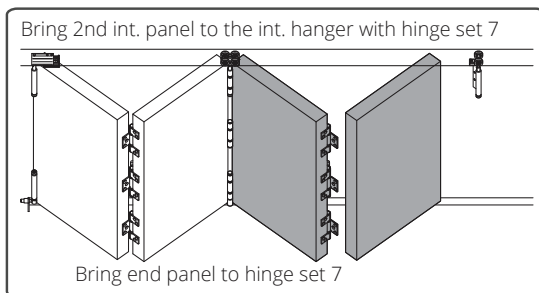
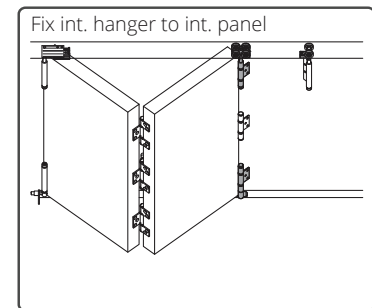
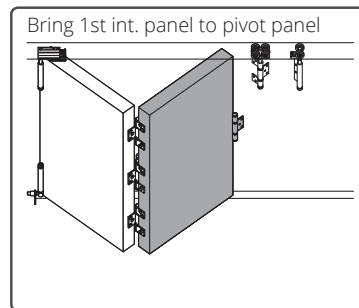
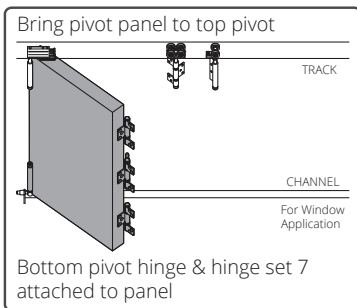
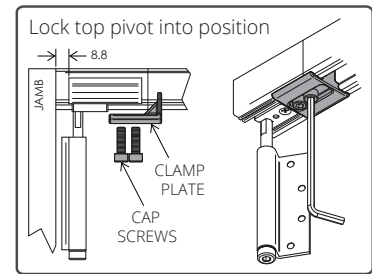
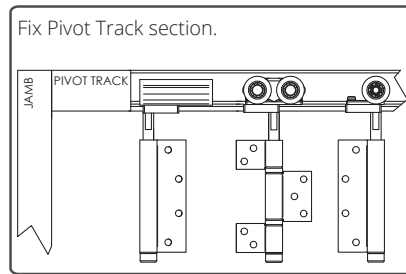
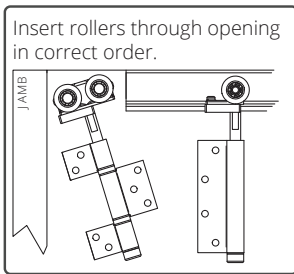

* 4 + 0 set shown

ADJUSTMENT

HANGER BOLT LOCKING BLOCK APPLIED TO ALL HANGERS AND TOP PIVOT

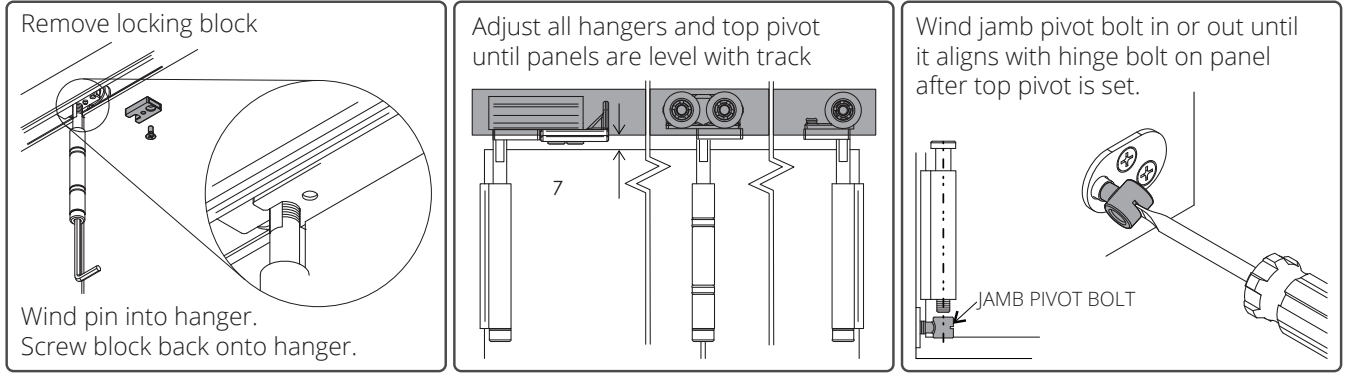

SYSTEM OVERVIEW

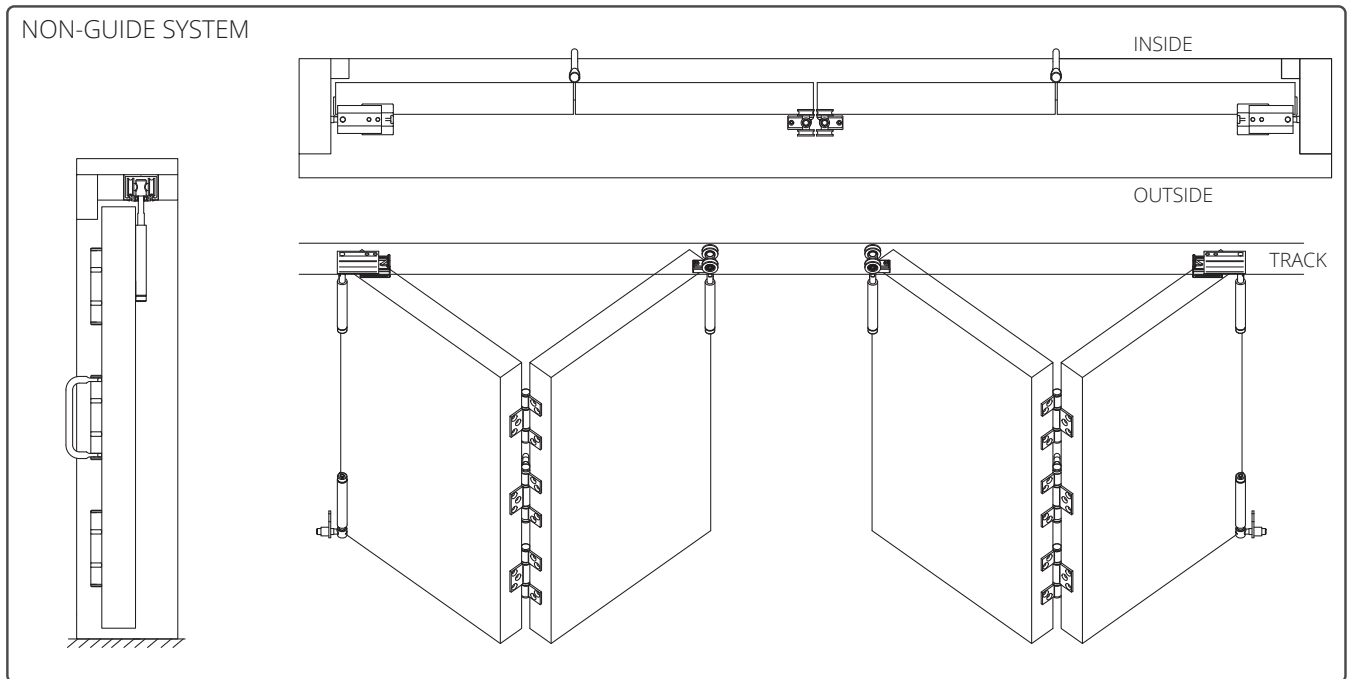

Hardware is subject to deterioration from everyday use and from the environment that it is in. In particular, it is important that routine maintenance be carried out in harsh coastal or marine environments and industrial applications.

GENERAL

Inspect all fixing bolts for tightness every six months, including those securing brackets. Tighten if necessary. Routinely check for wear and if excessively worn, the part should be replaced.

To help prevent surface corrosion, Deanta recommends washing regularly; even stainless steel finishes in coastal environments may show signs of surface corrosion if not washed regularly. Sheltered areas that are not rain washed are particularly susceptible. Wash with soap or mild detergent and warm water followed by rinsing with clean cold water and wipe dry.

As a guide, if a window or door requires washing then wash the hardware, however recommend for marine and industrial environments washing a minimum of every 3 months and 6 months for general environments. In coastal or marine environments recommends applying a light application of corrosion preventative such as CRC Marine 66 or Inox for Marine, to all surfaces and using a dry cloth to remove excess. When using lubricant or corrosion protection compounds, be careful to avoid the adjacent surfaces and always follow the manufacturer's instructions.

TRACK

Keep track free from obstruction and excessive dirt or water. Visible surfaces should be cleaned using a damp cloth and mild detergent, then wiped dry.

Where fitting to the outside of the building, it is recommended that the appropriate track is specified.

HANGERS & PIVOTS

All hangers are fitted with lubricated ball-bearings or plain bearings, requiring no greasing. If doors 'settle' and door clearance is reduced causing friction, raise the door by the hanger adjustment nuts.

Wash as per the above recommendation and apply a light application of corrosion preventative to all surfaces, using a dry cloth to remove excess.

GUIDES

Guide roller and guide channel must be kept clear and free of obstructions.

Wash as per the above recommendation and apply a light application of corrosion preventative to all surfaces, using a dry cloth to remove excess.

ROLLERS

All bottom rails should be free from obstruction and excessive dirt or water. Visible surfaces should be cleaned using a damp cloth and mild detergent, then wiped dry. All rollers are fitted with sealed precision bearings requiring no maintenance.

HINGES

Visible surfaces should be cleaned using a damp cloth and mild detergent, then wiped dry. Apply a light application of corrosion preventative to all surfaces, using a dry cloth to remove excess. Repeat at intervals no greater than 3 months.

FLUSH BOLTS

Visible surfaces should be cleaned using a damp cloth and mild detergent, then wiped dry. Apply a light application of lubricant to internal mechanisms and bolt using a suitable nozzle-spray.